

29-30-31 MARZO 1984

68^a TARGA

Flaminio

RALLYE INTERNAZIONALE DI SICILIA

**CAMPIONATO
AUTOBIANCHI**

CAMPIONATO D'EUROPA CONDUTTORI
CAMPIONATO OPEN D'ITALIA

CARNET DE BORD

FIAMM



INDUSTRIA ITALIANA
PETROLI

SICILICASSA
CASSA DI RISPARMIO V.E.
PER LE PROVINCE SICILIANE



LE PRESENTI NOTE SONO STATE REDATTE NEL MESE DI NOVEMBRE 1983
EVENTUALI MODIFICHE SOPRAVVENUTE NELLO STATO DELLE STRADE NON
SONO DA ADDEBITARE AI REDATTORI.

È STATO USATO UN TWIN-MASTER "HALDA" TARATO SULL'AUTOSTRADA
"A/19 - PALERMO CATANIA" DAL KM. 4,00 AL KM. 7,00 E DAL KM.
9,00 AL KM. 14,00 CON I SEGUENTI RILEVAMENTI:

- 1^A RILEVAZIONE: KM. 3,080
- 2^A RILEVAZIONE: KM. 5,100 SCARTO MEDIO 1,96%

CES NOTES ONT ETE REDIGE DANS LEMOIS DE NOVEMBRE 1983
DES EVENTUELS MODIFICATIONS ENTRE-TEMPS SURVENUS DANS LES
CONDITIONS DES ROUTES NE SONT PAS A ATTRIBUER AUX REDACTEURS.
NOUS AVONS UTILISE UN TWIN-MASTER "HALDA" ETALONNE SUR L'AUTO-
ROUTE "A/19 - PALERMO CATANIA" DU KM. 4,00 AU KM. 7,00 ET DU
KM. 9,00 AU KM. 14,00 AVEC LES SUIVANTS RELEVAMENTS:

- 1^{ER} RELEVAMENT KM. 3,080
- 2^{EME} RELEVAMENT KM. 5,100 ECART MOYEN 1,96%

THESE NOTES WHERE WRITTEN IN NOVEMBER 1983
ANY CHANGE IN VIABILITY CONDITIONS IS NOT TO BE CHARGED TO US.
A TWIN-MASTER "HALDA" ADJUSTED ON THE "A/19 - PALERMO CATANIA"
FROM KM. 4,00 AU KM. 7,00 AND FROM KM. 9,00 TO KM. 14 WITH THE
FOLLOWING RECORDING DATA:

- 1ST RECORDING: KM. 3,080
- 2ND RECORDING: KM. 5,100 AVERAGE DIFFERENCE 1,96%

TARGA FLORIO ROAD BOOK
- LEGENDA/LEGENDE/LEGEND -

	SEGUIRE L'INDICAZIONE SUIVRE L'INDICATION FOLLOW DIRECTION		CANCELLO GRILLE GATE
	RIFERIMENTO POINT DE REPERE		
	LANDMARKS		PONTE PONT BRIDGE
	TERRA TERRE NO ASPHALT ROAD		TUNNEL TUNNEL TUNNEL
	ATTENZIONE - MOLTA ATTENZIONE ATTENTION - BEAUCOUP D'ATTENTION TAKE CARE - TAKE GREAT CARE		FERROVIA CHEMIN DE FER RAILWAY
	DISTRIBUTORE DI CARBURANTE STATION DE SERVICE PETROL PUMP		SALITA - DISCESA MONTEE - DESCENTE GO UP - DOWNHILL
	CARRO ATTREZZI DEPANNEUSE BREAKDOWN VAN		SEMAFORO SEMAPHORE TRAFFIC LIGHT
	AMBULANZA AMBULANCE AMBULANCE		CAPPELLA CHAPELLE CHAPEL
	RADIO RADIO RADIO TRANSMITTER		CABINA ELETTRICA CABINE ELECTRIQUE ELECTRIC CABIN
	LOCALITÀ PANNEAU DE LOCALITE LOCALITY		CASA MAISON HOUSE
	FINE LOCALITÀ FIN DE LOCALITE LOCALITY END		SEGNALE DI DIREZIONE PANNEAU DE DIRECTION DIRECTIONAL PANEL
	LOCALITÀ PAESE LOCALITEE - VILLAGE LOCALITY - TOWN		DIREZIONE SBAGLIATA DIRECTION BARRÉ SIGN <u>NOT</u> OUR WAY
	CARTELLI STRADALI PANNEAUX DE SIGNALISATION ROAD SIGN		SEGNALE DI PRECEDENZA ROUTE A PRIORITÉ PRECEDENCE SIGNAL
	SEGNALE DI STOP STOP HALT		PROVE SPECIALI EPREUVES DE CLASSEMENT SPECIAL STAGES
	FONDO STRADALE DISSESTATO O FRANATO CHUSSEE DEFORMEE OU CHUTE ROAD-SURFACE IN BAD CONDITION OR SLIDING DOWN		

TROFEO A112

STAMPATO DA
 FULCO

I N D I C E

SETTORE 1 - C.H.22	CEFALÙ LUNGOMARE	C.H.23	SCIARA		PAG. 1
SETTORE 2 - C.H.23	SCIARA	C.H.24	MONTEMAGGIORE	P.S.A/2	PAG. 9
SETTORE 3 - C.H.24	MONTEMAGGIORE	C.H.25	VILLAUREA	P.S.B/3	PAG.12
SETTORE 4 - C.H.25	VILLAUREA	C.H.26	COLLESANO	P.S.C/3	PAG.19
SETTORE 5 - C.H.26	COLLESANO	C.H.27	SANTA LUCIA	P.S.D/3	PAG.25
SETTORE 6 - C.H.27	SANTA LUCIA	C.H.28	FERLA	P.S.E/2	PAG.30
SETTORE 7 - C.H.28	FERLA	C.H.29	LASCARI RIORD.	P.S.F/2	PAG.34
SETTORE 8 - C.H.29	LASCARI RIORD.	C.H.30	LASCARI RIORD.		PAG.42
SETTORE 9 - C.H.30	LASCARI RIORD.	C.H.31	S.P. 9	P.S.G/3	PAG.43
SETTORE 10 - C.H.31	S.P. 9	C.H.41	CEFALÙ LUNGOMARE	P.S.H/2	PAG.47
SETTORE 11 - C.H.41	CEFALÙ LUNGOMARE	C.H.42	CEFALÙ P. CHIUSO		PAG.53

SECTEUR

1

CH22 CEFALU' LUNGOMARE

CH23 SCIARA

moy. 42,760

distance 57,020

temps impartì 1^H 20'

distance

tot.

part.

direction

informations

dist. tot. regress.

0,00

0,00

1

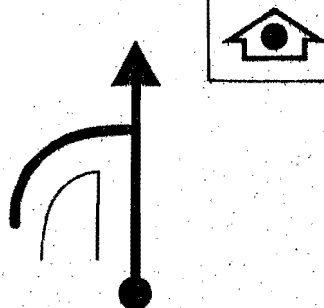

● Hotel



57,02

0,08

0,08

2

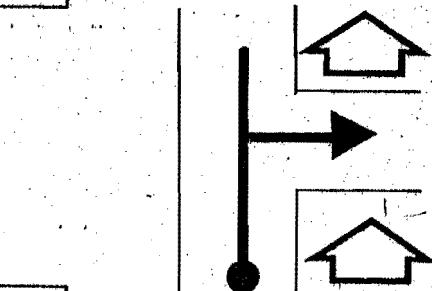

▶ via Archimede

56,94

0,21

0,13

3

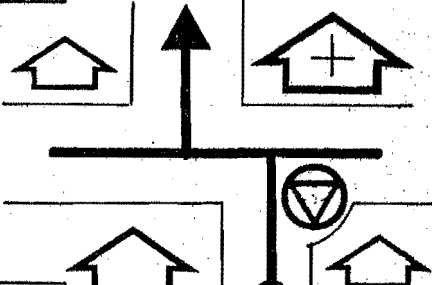

▶ via S. Pasqualino

56,81

0,36

0,15

4

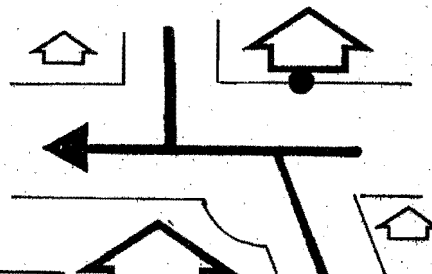

▶ c.so Umberto



56,66

0,43

0,07

5

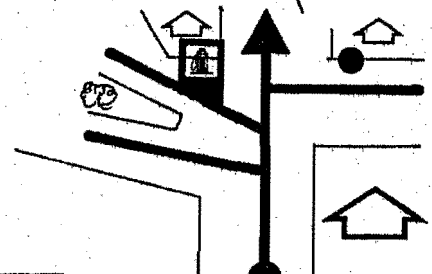

▶ CEFALU' STAZIONE



56,59

CH 22 - CEFALU'

CH 23 - SCIARA



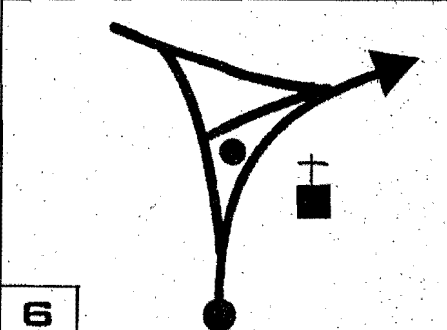
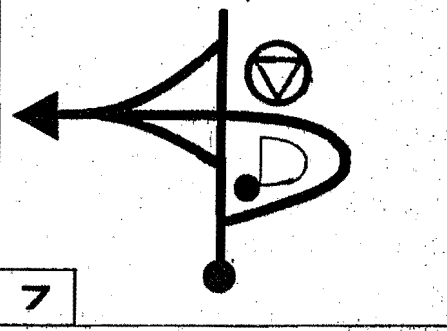
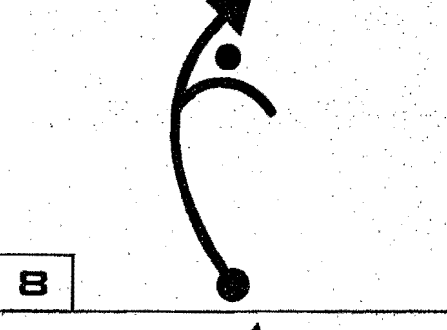
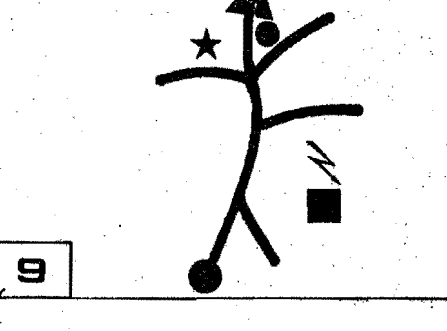
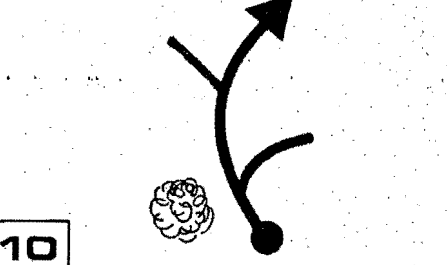





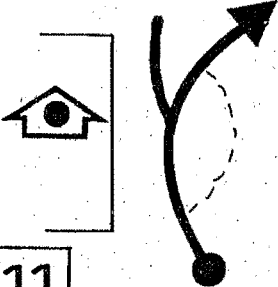

KM. 57,020 - 1^H 20'

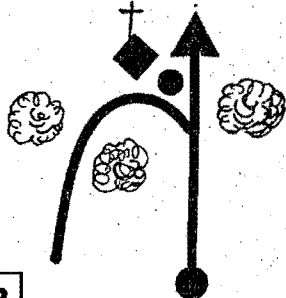
distance		direction	informations	dist. tot. regress.
tot.	part.			
0,88	0,45	6 	<ul style="list-style-type: none"> ● MESSINA ▶ A19 CATANIA ▶ A20 PALERMO 	56,14
1,69	0,81	7 	<ul style="list-style-type: none"> ▶ A DX - per GIBILMANNA ● GIBILMANNA 	55,33
2,66	0,97	8 	<ul style="list-style-type: none"> ● CROCE FARRINO 	54,36
10,09	7,43	9 	<ul style="list-style-type: none"> ● GIBILMANNA ▶ PRESTI ★ CARBONARA 	46,93
10,99	0,90	10 		46,03

CH 22 - CEFALU'

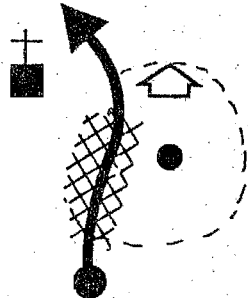
CH 23 - SCIARA

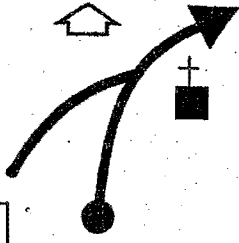
Km. 57,020 - 1^H 20'

distance		direction	informations	dist. tot. regress.
tot.	part.			
13,85	2,86	 11	● Hotel BEL SOGGIORNO 	43,17
14,72	0,87	 12	● ISNELLO COLLESANO GRATTERI 	42,30
15,33	0,61	 13	● ISNELLO CASTELBUONO COLLESANO GRATTERI LASCARI  	41,69
18,86	3,53	 14	● CAVA  	38,16
20,60	1,74	 15	(GRATTERI) 	36,42

CH 22 - CEFALU'

CH 23 - SCIARA

DEUICOLA
URT











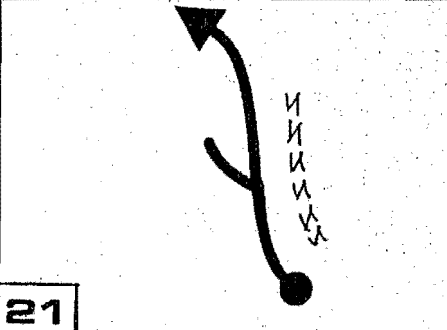

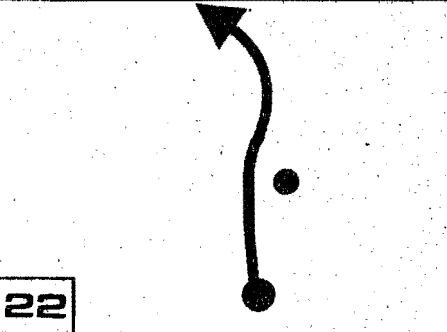

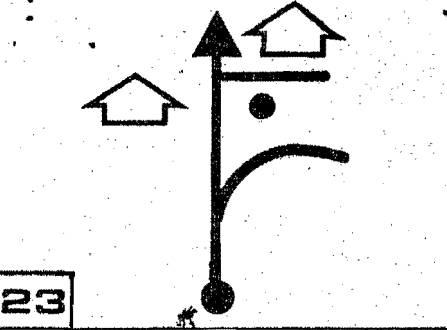
KM. 57.020 - 1^H 20'

distance		direction	informations	dist. tot. regress.
tot.	part.			
20,70	0,10	 16	● abbeveratoio ●	36,32
20,82	0,12	 17	 	36,20
21,19	0,37	 18	● fontana ★ 	35,83
21,51	0,32	 19	● 	35,51
23,15	1,64	 20		33,87

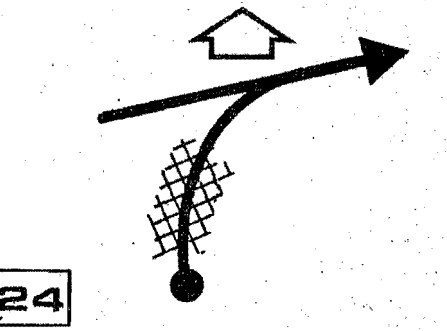
CH 22 - CEFALU'

CH 23 - SCIARA

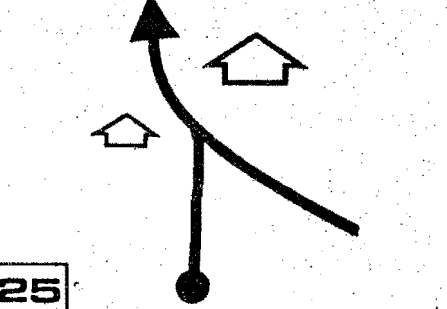



KM. 57,020 - 1^H 20'

distance		direction	informations	dist. tot. regress.
tot.	part.			
25,87	2,72			31,15
32,52	6,65		 LASCARI 	24,50
32,73	0,21		 CARABINIERI  	24,29
33,50	0,77		 per ml.100  	23,52
33,61	0,11			23,41

CH 22 - CEFALU'

CH 23 - SCIARA

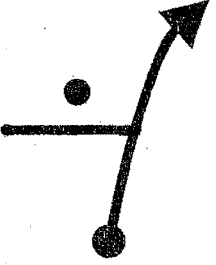
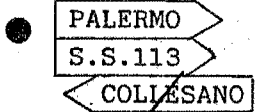
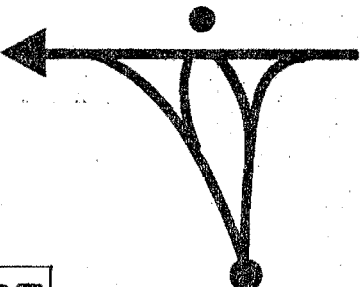
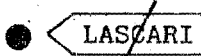
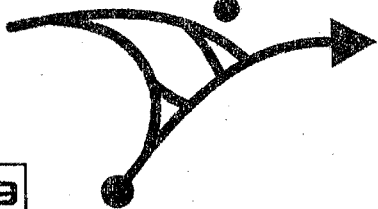
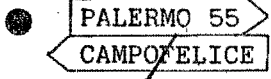
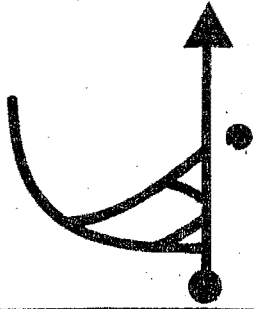
Km. 57,020 - 1^H 20'

distance		direction	informations	dist. tot. regress.
tot.	part.			
33.89	0.28	 26		23.13
34.13	0.24	 27		22.89
35.09	0.96	 28		21.93
40.14	5.05	 29		16.88
44.11	3.97	 30		12.91

240

CH 22 - CEFALU'

CH 23 - SCIARA

KM. 57,020 - 1^H 20'

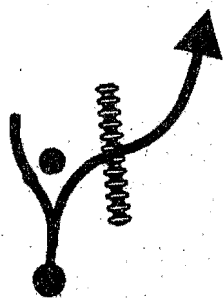
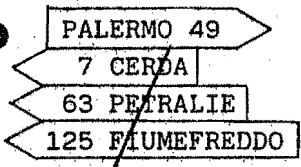
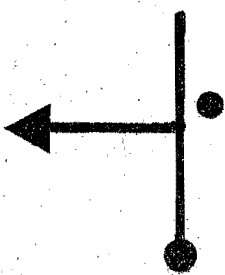
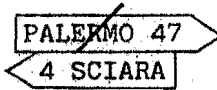
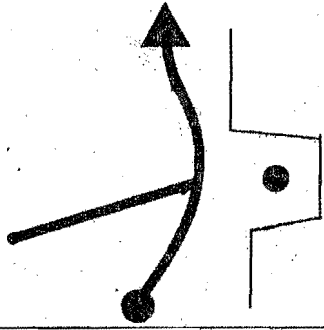
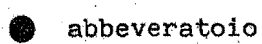
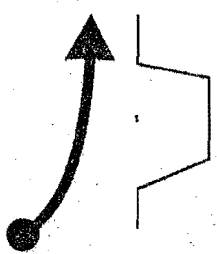
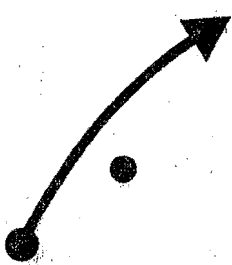
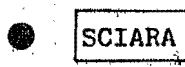
distance		direction	informations	dist. tot. regress.
tot.	part.			
50,39	6,28	 31	 49	6,63
51,71	1,32	 32		5,31
54,90	3,19	 33		2,12
55,32	0,42	 34		1,70
56,05	0,73	 35		0,97

CH 22 - CEFALU'

CH 23 - SCIARA

KM. 57,020 - 1^H 20'

distance		direction	informations	dist. tot. regress.
tot.	part.			
56,34	0,29	 36	c.so Umberto	0,68
56,84	0,50	 37	via Giardinello <ul style="list-style-type: none"> ▶ AGRIGENTO ▶ CALTANISSETTA ▶ ENNA ▶ CATANIA 	0,18
56,93	0,09	 38		0,09
57,02	0,09	 39	23	0,00

SECTEUR

2

CH23 SCIARA

CH24 MONTEMAGGIORE

noy.

40,906

distance

11,670

temps
imparti

17'

distance

direction

informations

dist. tot.
regress.

tot.

part.

0.00

0.00

1

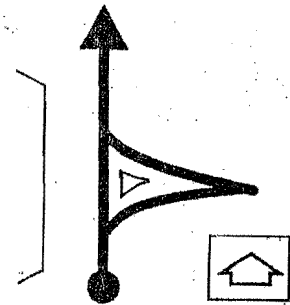

23

11.67

0.08

0.08

2

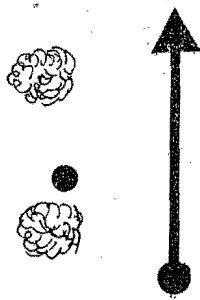

SCIARA



A2

11.59

1.31

1.23

3

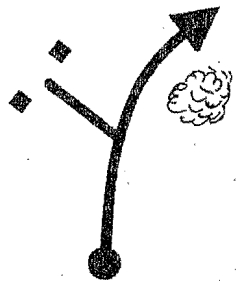

10.36

3.33

2.02

4

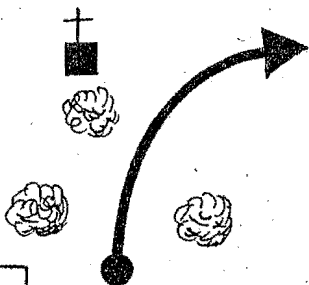

8.34

4.52

1.19

5

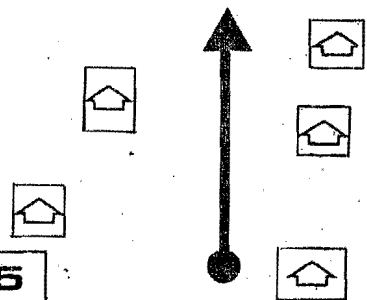







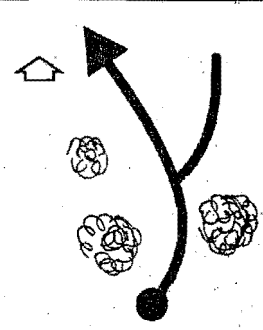

7.15

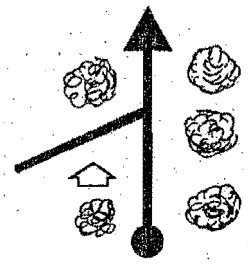
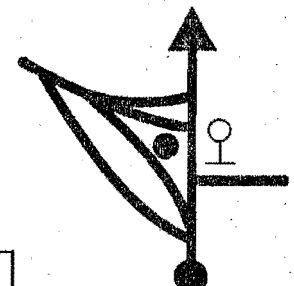
CH 23 - SCIARA

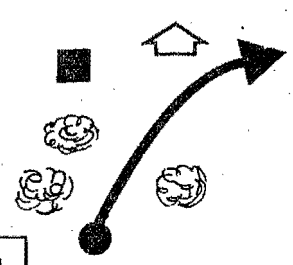
CH 24 - MONTEMAGGIORE

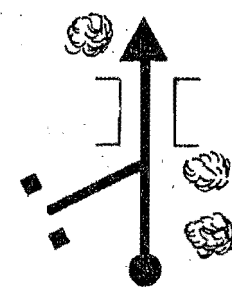





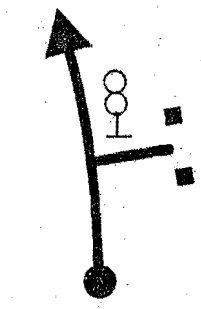

KM. 11,670 - 17'

distance		direction	informations	dist. tot. regress.
tot.	part.			
5.22	0.70	 6		6.45
5.49	0.27	 7		6.18
5.67	0.18	 8		6.00
5.93	0.26	 9		5.74
9.81	3.88	 10		1.86

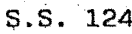
CH 23 - SCIARA

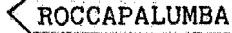
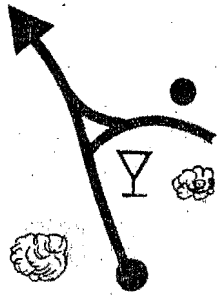
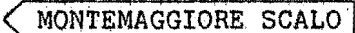
CH 24 - MONTEMAGGIORE

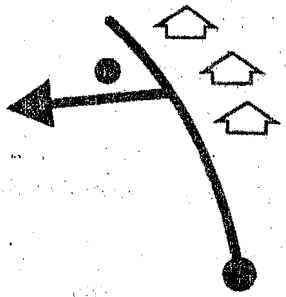
KM. 11,670 - 17'

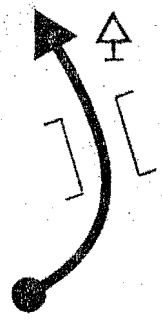
distance		direction	informations	dist. tot. regress.
tot.	part.			
10.10	0.29	11 	     	1.57
10.27	0.17	12 	   <i>140</i>	1.40
11.45	1.18	13 	<i>24</i>  24 	0.22
11.67	0.22	14 		0.00

+5

140

24



SECTEUR

3

CH 24 MONTEMAGGIORE

CH 25 VILLAUREA

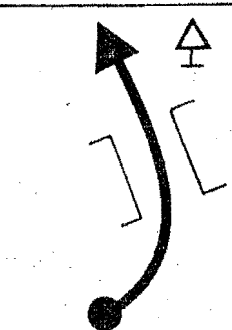

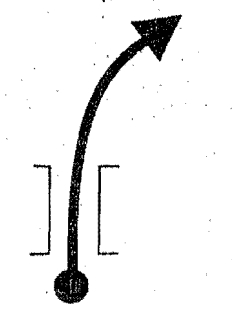
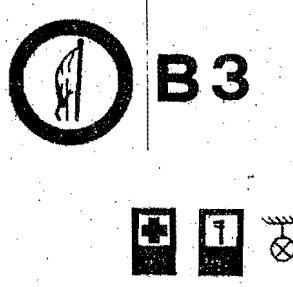
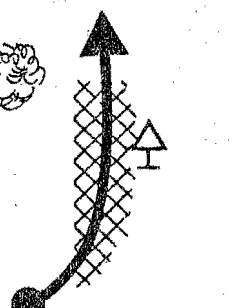
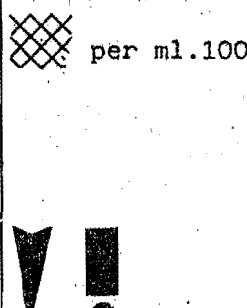
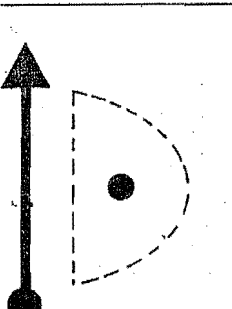
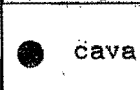
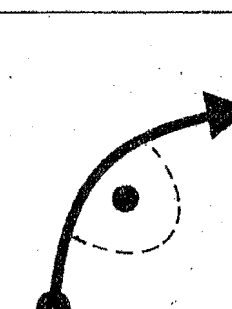
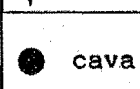



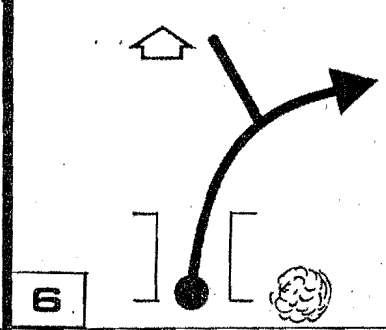
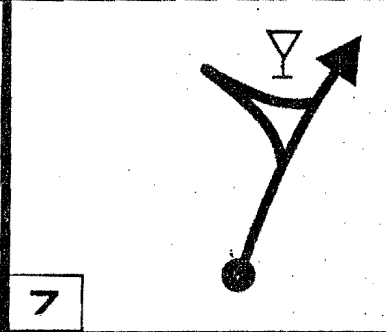

moy.	42,369
distance	36,800
temps impartis	52'

distance		direction	informations	dist. tot. regress.
tot.	part.			
0.00	0.00			36,80
0.08	0.08			36,72
0.58	0.50			36,22
1.38	0.80			35,42
1.71	0.33			35,09

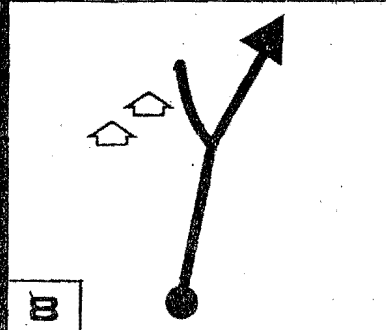
CH 24 - MONTEMAGGIORE

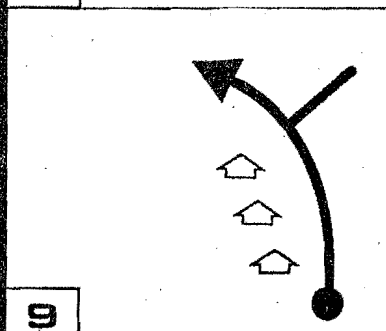
CH 25 - VILLAURA

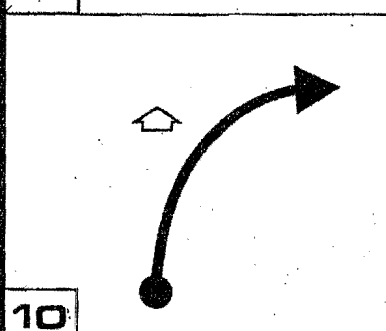









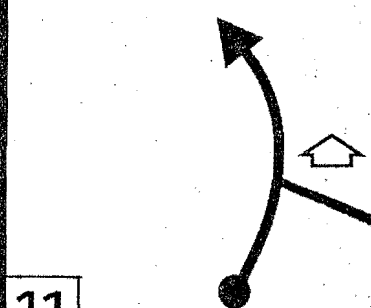

KM. 36.800 - 52'

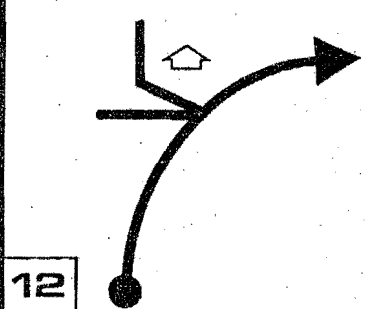
distance		direction	informations	dist. tot. regress.
tot.	part.			
2,08	0,37			34,72
3,03	0,95			33,77
5,17	2,14			31,63
5,80	0,63			31,00
6,84	1,04			29,96

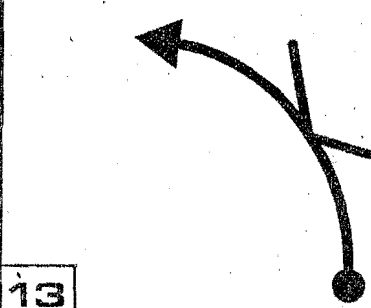
CH 24 - MONTEMAGGIORE

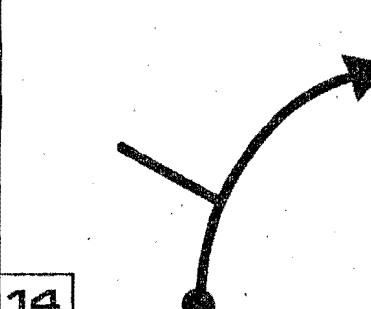
CH 25 - VILLAUREA

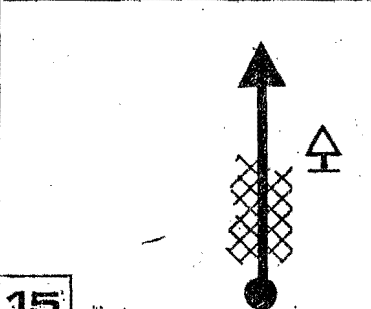









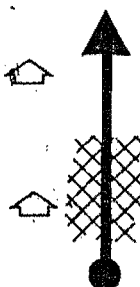

KM. 36,800 - 52'

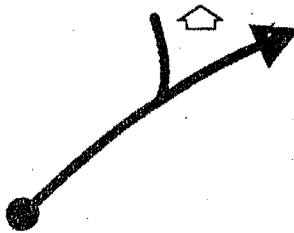
distance		direction	informations	dist. tot. regress.
tot.	part.			
8.62	1.78	 11	POSTAZIONE INTERMEDIA    	28.18
9.59	0.97	 12		27.21
11.13	1.54	 13	 	25.67
11.83	0.70	 14		24.97
12.55	0.72	 15	 per ml.160 	24.25

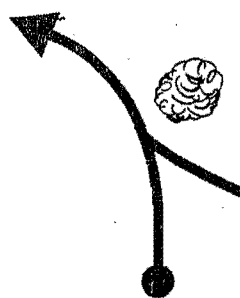
CH 24 - MONTEMAGGIORE

CH 25 - VILLAUREA

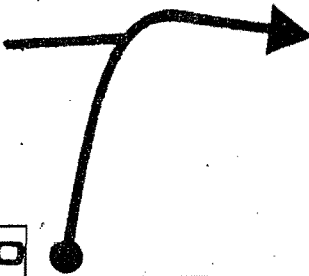





Km. 36,800 - 52'

distance		direction	informations	dist. tot. regress.
tot.	part.			
12,93	0,38	 16	 per ml.200 	23,87
13,55	0,62	 17		23,25
14,23	0,68	 18		22,57
15,47	1,24	 19	POSTAZIONE INTERMEDIA    	21,33
15,92	0,45	 20		20,88

CH 24 - MONTEMAGGIORE

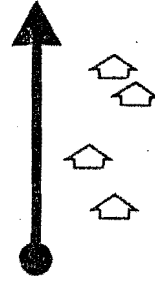
CH 25 - VILLAUREA

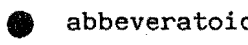
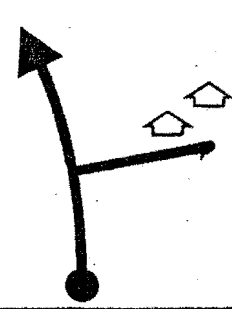









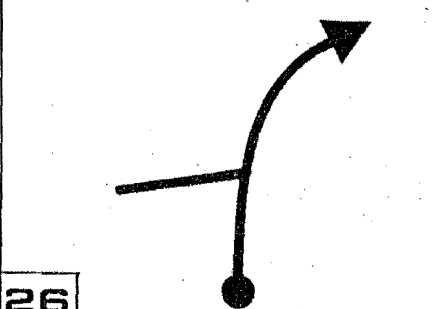

Km. 36,800 - 52'

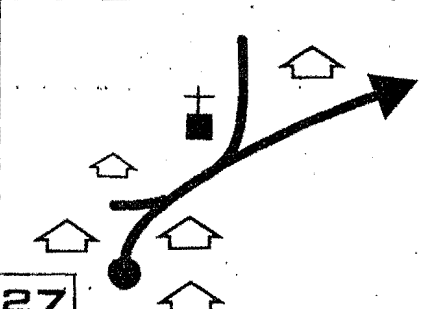
distance		direction	informations	dist. tot. regress.
tot.	part.			
16,73	0,81			20,07
20,14	3,41			16,66
22,12	1,98			14,68
23,55	1,43			13,25
24,31	0,76		 	12,49

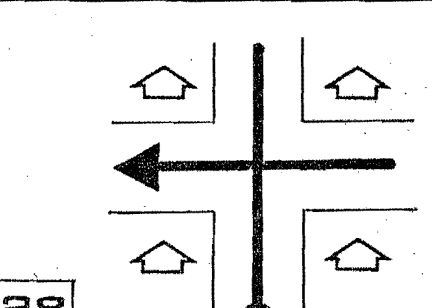
CH 24 - MONTEMAGGIORE

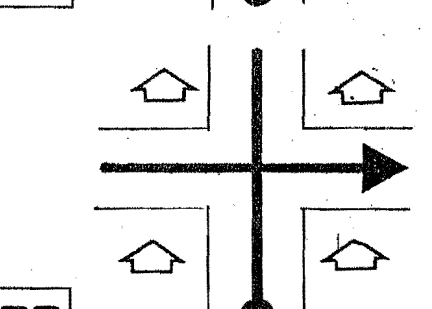
CH 25 - VILLAUREA

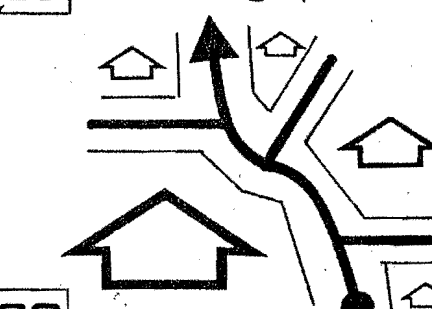
Km. 36,800 - 52'

distance		direction	informations	dist. tot. regress.
tot.	part.			
24,58	0,27	 26	  	12,22
25,15	0,57	 27	 c.so Re Galantuomo 	11,65
25,74	0,59	 28	 via Marchesano 	11,06
25,84	0,10	 29	 	10,96
25,90	0,06	 30	 via Palermo	10,90

CH 24 - MONTEMAGGIORE

CH 25 - VILLAUREA

Km. 36,800 - 52'

distance		direction	informations	dist. tot. regress.
tot.	part.			
26.53	0.63		<ul style="list-style-type: none"> ● MONTEMAGGIORE 	10.27
28.32	1.79		<ul style="list-style-type: none"> ▶ c.so Generale Grisanti ● ALIMINUSA 	8.48
29.01	0.69		<ul style="list-style-type: none"> ● ALIMINUSA 	7.79
35.15	6.14		<ul style="list-style-type: none"> ▶ S.S.120 ▶ PALERMO ▶ BIVIO CERDA ▶ CALTAVUTURO ▶ FIUMEFREDDO ▶ NICOSIA ▶ PETRALIE <p style="text-align: right;">(15')</p>	1.65
36.8	1.65			0.00

SECTEUR

4

CH 25 VILLAUREA

CH 26 COLLESANO

moy.

43,132

distance

38,210

temps
imparti

53'

distance

direction

informations

dist. tot.
regress.

tot.

part.

0.00

0.00

1

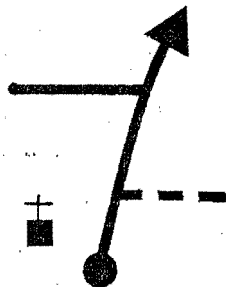

25

38,21

0.11

0.11

2



C 3



38,10

1,36

1,25

3



36,85

1,95

0,59

4



36,26

6,64

4,69

5

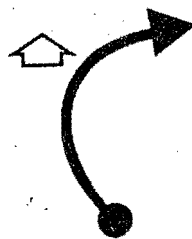







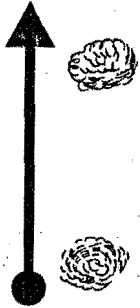

31,57

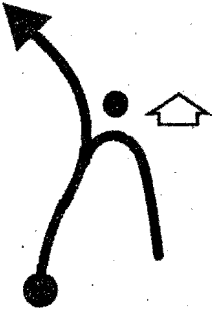
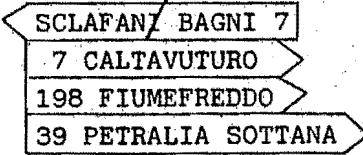
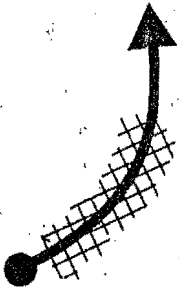
CH 25 - VILLAUREA

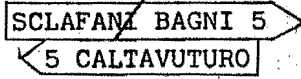
CH 26 - COLLESANO

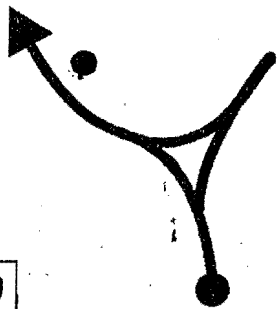
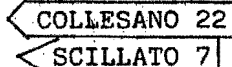









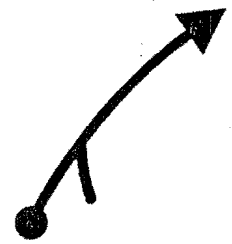

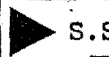
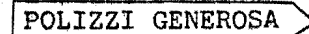

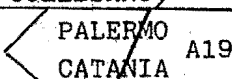

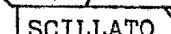
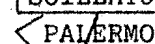

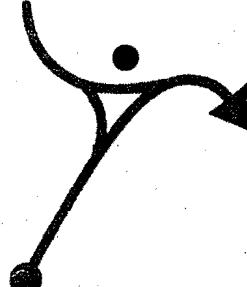
KM. 38,210 - 53'

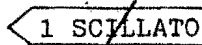
distance		direction	informations	dist. tot. regress.
tot.	part.			
9,83	3,19	6 	POSTAZIONE INTERMEDIA 	28,38
12,09	2,26	7 		26,12
12,66	0,57	8 	frana 	25,55
13,70	1,04	9 	 	24,51
16,76	3,06	10 	S.P. 24  POSTAZIONE INTERMEDIA 	21,45

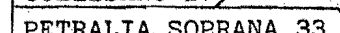
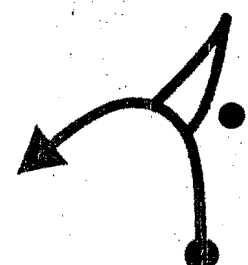
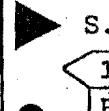
CH 25 - VILLAUREA

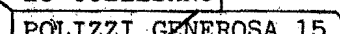
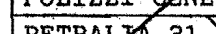
CH 26 - COLLESANO









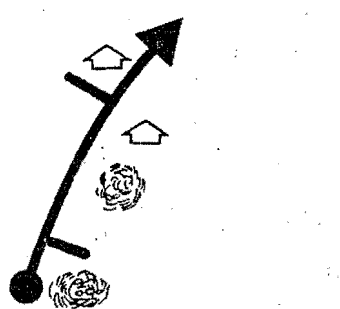

Km. 38,210 - 53'

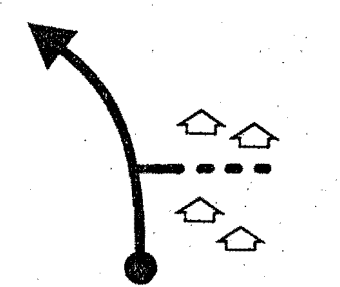
distance		direction	informations	dist. tot. regress.
tot.	part.			
23,69	6,93	11 		14,52
24,59	0,90	12 	 S.S. 643      	13,62
24,89	0,30	13 		13,32
24,99	0,10	14 	    	13,22
27,05	2,06	15 	 S.P. 9    POSTAZIONE INTERMEDIA   	11,16

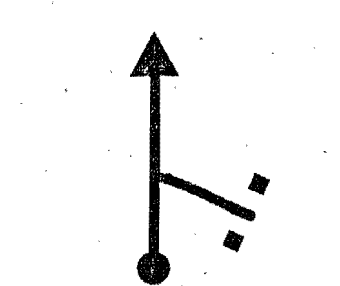
CH 25 - VILLAUREA

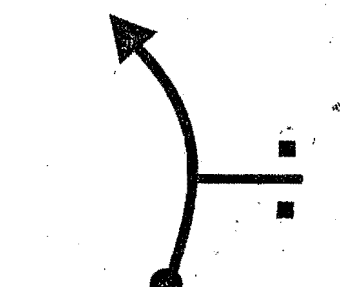
CH 26 - COLLESANO

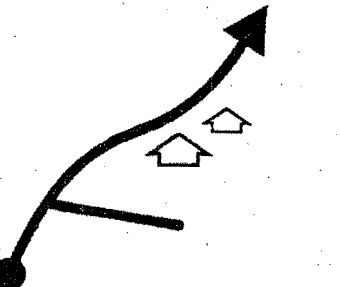
KM. 38,210 - 53'

distance		direction	informations	dist. tot. regress.
tot.	part.			
30,24	3,19	16 		7,97
31,55	1,31	17 		6,66
34,43	2,88	18 		3,78
34,63	0,20	19 		3,58
35,87	1,24	20 	 C3	2,34

CH 25 - VILLAUREA

CH 26 - COLLESANO

Km. 38,210 - 53'

distance		direction	informations	dist. tot. regress.
tot.	part.			
36.05	0.18	 21	● COLLESANO 	2.16
36.74	0.69	 22	● via Roma-c.so Vitt.Eman.	1.47
36.91	0.17	 23	 p.zza Garibaldi	1.30
37.48	0.57	 24		0.73
37.54	0.06	 25		0.67

+20

CH 25 - VILLAUREA

CH 26 - COLLESANO

Km. 38,210 - 53'

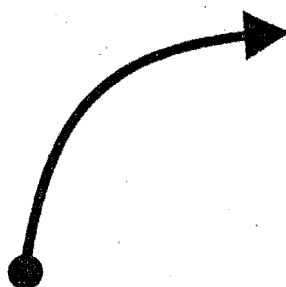
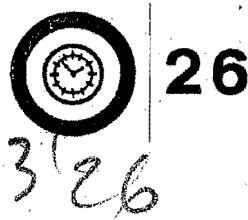
distance		direction	informations	dist. tot. regress.
tot.	part.			
38,21	0,67	26 		0,00
		<input type="checkbox"/>		
		<input type="checkbox"/>		
		<input type="checkbox"/>		
		<input type="checkbox"/>		

SECTEUR

5

CH 26 COLLESANO

CH 27 SANTA LUCIA

long.







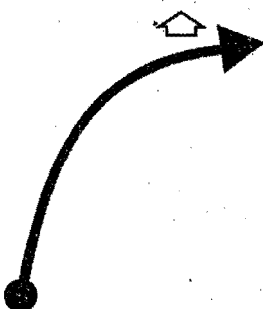
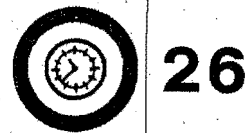
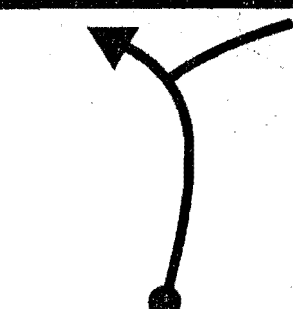

39,466

distance

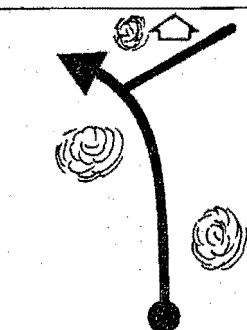
23,740

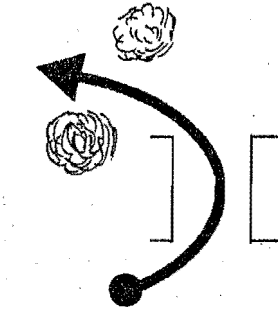
temps
imparti

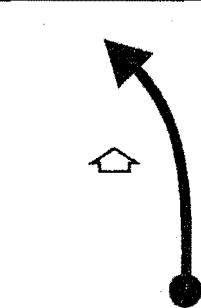







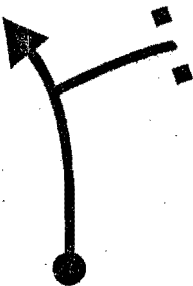

36'

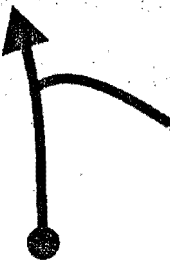
distance		direction	informations	dist. tot. regress.
tot.	part.			
0,00	0,00			23,74
0,06	0,06		 	23,68
0,30	0,24			23,44
1,99	1,69			21,75
3,72	1,73			20,02

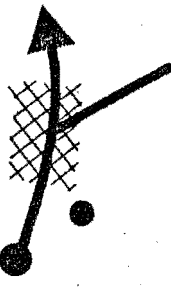
CH 26 - COLLESANO

CH 27 - SANTA LUCIA

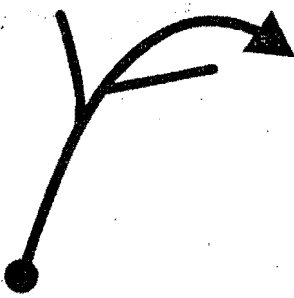







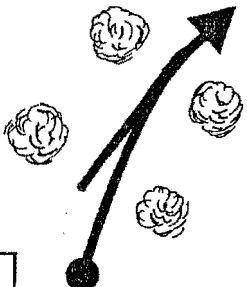

Km. 23,740 - 36'

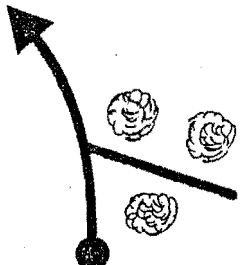
distance		direction	informations	dist. tot. regress.
tot.	part.			
5,40	1,68	6 		18,34
6,14	0,74	7 		17,60
6,72	0,58	8 	per ml.250 ● abbeveratoio POSTAZIONE INTERMEDIA  	17,02
7,46	0,74	9 		16,28
9,03	1,57	10 		14,71

CH 26 - COLLESANO

CH 27 - SANTA LUCIA

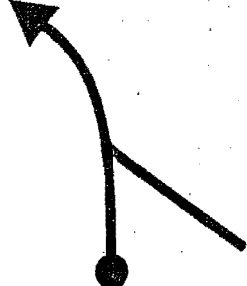
Km. 23,740 - 36'

distance		direction	informations	dist. tot. regress.
tot.	part.			
12,40	3,37			11,34
13,40	1,00			10,34
13,43	0,03			10,31
13,94	0,51		 	9,8
14,19	0,25		 	9,55

CH 26 - COLLESANO

CH 27 - SANTA LUCIA

Km. 23,740 - 36'

distance		direction	informations	dist. tot. regress.
tot.	part.			
14,64	0,45			9,10
15,61	0,97			8,13
18,89	3,28			4,85
20,60	1,71			3,14
23,21	2,61			0,53

CH 26 - COLLESANO

CH 27 - SANTA LUCIA

Km. 23,740 - 36'

distance		direction	informations	dist. tot. regress.
tot.	part.			
23,33	0,12	 <div style="border: 1px solid black; padding: 2px; display: inline-block;">21</div>	● hotel	0,41
23,74	0,41	 <div style="border: 1px solid black; padding: 2px; display: inline-block;">22</div>	 <div style="border: 1px solid black; padding: 2px; display: inline-block;">27</div>	0,00









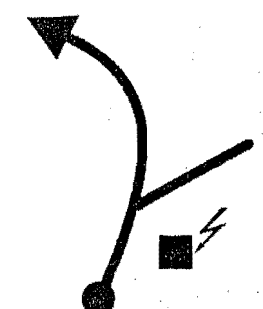

SECTEUR 6	CH27 SANTA LUCIA	moy. 36,548
	CH28 FERLA	distance 21,380
		temps impartì 35'

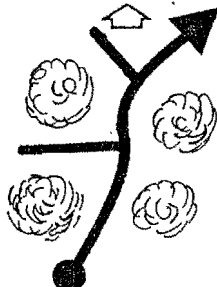
distance		direction	informations	dist. tot. regress.
tot.	part.			
0,00	0,00	1 		21,38
0,06	0,06	2 	 	21,32
0,25	0,19	3 		21,13
3,23	2,98	4 	 	18,15
4,84	1,61	5 		16,54

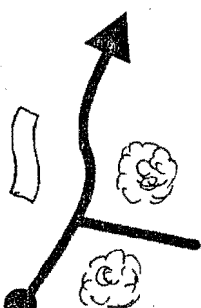
CH 27 - SANTA LUCIA

CH 28 - FERLA

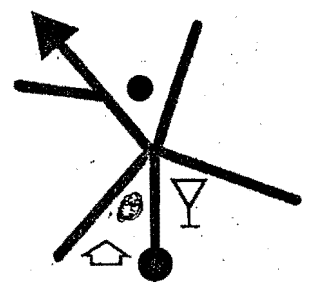





KM. 21,380 - 35'

distance		direction	informations	dist. tot. regress.
tot.	part.			
5,90	1,06	6 		15,48
8,79	2,89	7 		12,59
9,68	0,89	8 		11,70
9,89	0,21	9 		11,49
10,19	0,30	10 	<p>S.P. 9</p> <p>CEFALU'</p> <p>CARBONARA</p> <p>POSTAZIONE INTERMEDIA</p> 	11,19

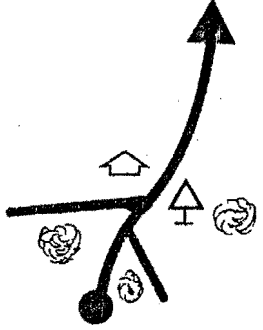
CH 27 - SANTA LUCIA

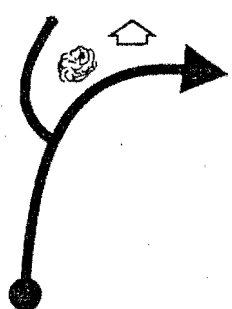
CH 28 - FERLA

Km. 21,380 - 35'

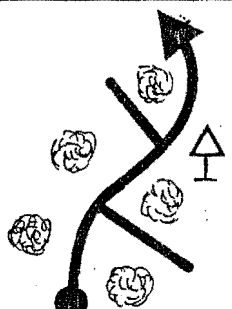
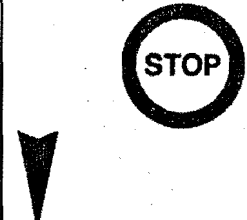
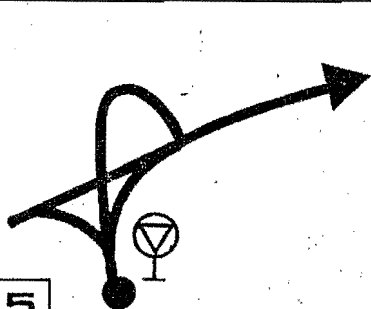
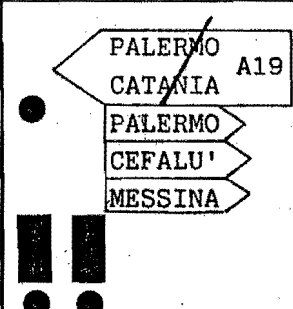
distance		direction	informations	dist. tot. regress.
tot.	part.			
13,06	2,87	11 		8,32
15,14	2,08	12 		6,24
17,15	2,01	13 		4,23
17,42	0,27	14 		3,96
18,49	1,07	15 		2,89

(+15)

CH 27 - SANTA LUCIA *ARBA GNA*

CH 28 - FERLA

Km. 21,380 - 35'

distance		direction	informations	dist. tot. regress.
tot.	part.			
19.30	0.81	16 	 S.S.113 A DX - PER FERLA PALEOMO CEFALU' MESSINA abbeveratoio 	2.08
20.44	1.14	17 	 CEFALU' CENTRO <i>260</i> hotel	0.94
21.05	0.61	18 	 FERLA 	0.33
21.38	0.33	19 	<i>330</i> 28	0.00

SECTEUR

7

CH28 FERLA

CH29 LASCARI
INIZIO RIORDINAMENTO

moy. 39,750

distance 31,880









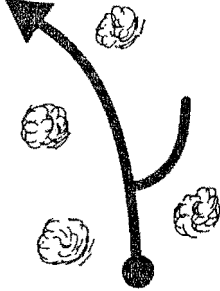

temps impartis 48'

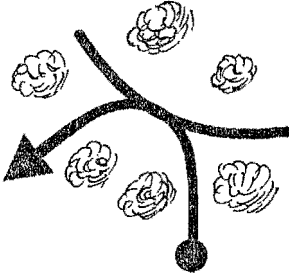
distance		direction	informations	dist. tot. regress.
tot.	part.			
0.00	0.00		28	31,88
0.08	0.08		F 2 	31,80
0.72	0.64			31,16
2.84	2.12			29,04
4.26	1.42			27,62

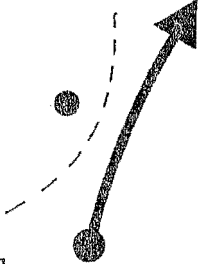
CH 28 - FERLA

CH 29 - LASCARI INIZIO RIORDINAMENTO

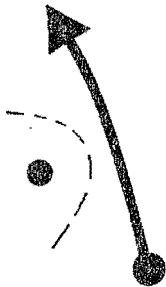
Km. 31,880 - 48'

distance		direction	informations	dist. tot. regress.
tot.	part.			
4,59	0,33			27,29
7,49	2,90			24,39
7,84	0,35		<p>● frana</p> 	24,04
7,91	0,07			23,97
7,95	0,04		<p>● frana</p> 	23,93

CH 28 - FERLA

CH 29 - LASCARI INIZIO RIORDINAMENTO

Km. 31,880 - 48'









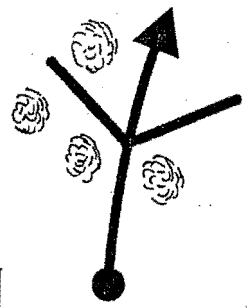

distance		direction	informations	dist. tot. regress.
tot.	part.			
8,15	0,20		per ml.50 	23,73
8,28	0,13			23,60
8,37	0,09			23,51
8,39	0,02		per ml.80 	23,49
9,03	0,64			22,85

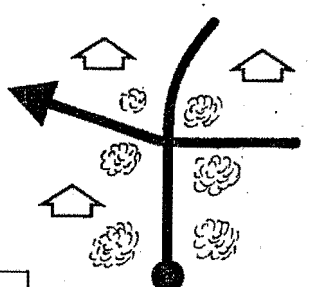
1251

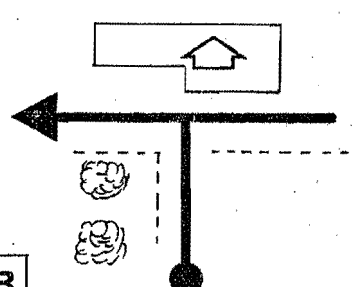
CH 28 - FERLA

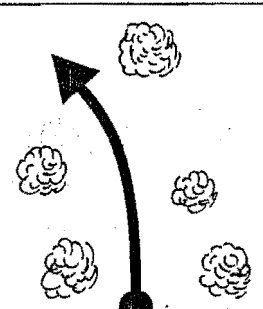
CH 29 - LASCARI INIZIO RIORDINAMENTO

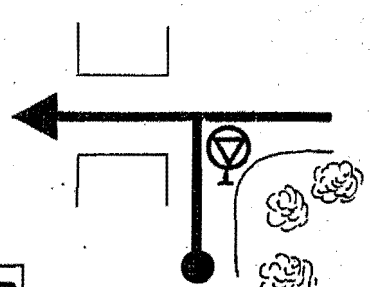
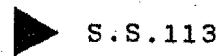

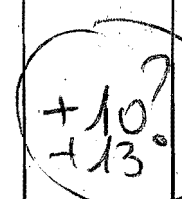







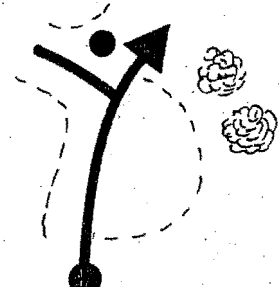

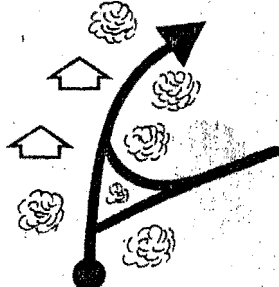

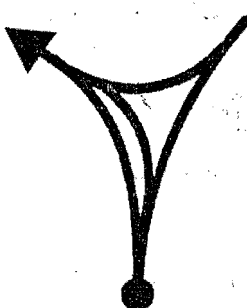

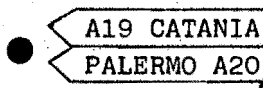
KM. 31,880 - 48'

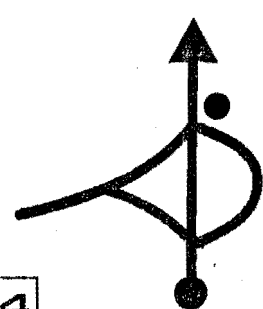
distance		direction	informations	dist. tot. regress.	
tot.	part.				
9,07	0,04	 16		22,81	
9,90	0,83	 17	<i>h'25</i> 	21,98	
10,28	0,38	 18	<i>6'</i> 	21,60	
11,57	1,29	 19		20,31	
12,95	1,38	 20	<i>115,</i>  	<i>6'</i> 	19,93

CH 28 - FERLA

CH 29 - LASCARI INIZIO RIORDINAMENTO

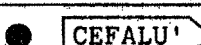









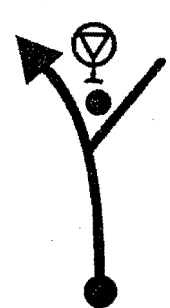

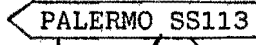
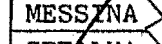



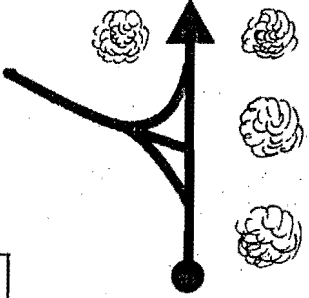
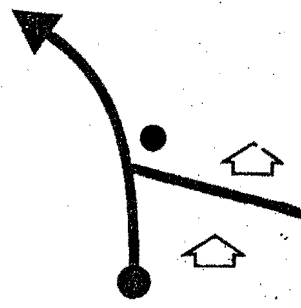

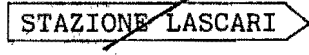
Km. 31,880 - 48'

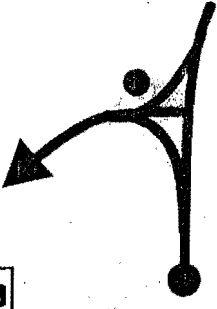
distance		direction	informations	dist. tot. regress.
tot.	part.			
15.48	2.53	21 	  <i>1550</i> <i>1330</i>	16.40
16.10	0.62	22 		15.78
17.22	1.12	23 	 S.P.9   <i>1555'</i>	14.66
18.02	0.80	24 	 AUTOSTRADA PA - ME   	13.86
23.38	5.36	25 	  	8.50

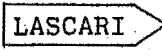
CH 28 - FERLA

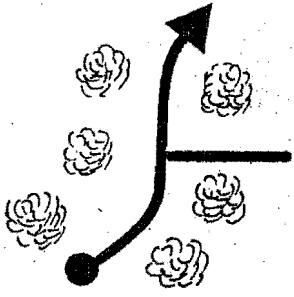
CH 29 - LASCARI INIZIO RIORDINAMENTO

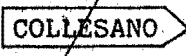
Km. 31,880 - 48'

distance		direction	informations	dist. tot. regress.
tot.	part.			
23,74	0,36	26 	 S.S.113      	+2'16 8,14
25,48	1,74	27 		6,40
28,31	2,83	28 	  3'20  	3,57
28,78	0,47	29 	 S.P.28 3'50    	3,10
29,79	1,01	30 	  4'45  	2,09

CH 28 - FERLA

CH 29 - LASCARI INIZIO RIORDINAMENTO

Km. 31,880 - 48'

distance		direction	informations	dist. tot. regress.
tot.	part.			
30,04	0,25			1,84
30,33	0,29			1,55
30,41	0,08			1,47
31,18	0,77			0,70
31,43	0,25			0,45



GRATTEN

650

CH 28 - FERLA

CH 29 - LASCARI INIZIO RIORDINAMENTO

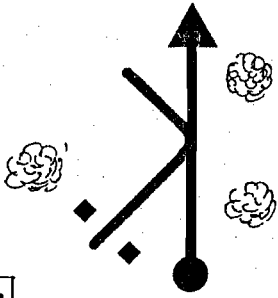
Km. 31,880 - 48'

distance		direction	informations	dist. tot. regress.
tot.	part.			
31.88	0.45		 735 29 	0.00
		!! OO RIORDINAMENTO CONTROLLARE LA TABELLA		

SECTEUR

8

CH29 LASCARI
INIZIO RIORDINAMENTO

CH30 LASCARI
FINE RIORDINAMENTO

moy.

distance

0,140

temps
imparti

15'

distance

tot.

part.

direction

informations

dist. tot.
regress.

0,00

0,00

1

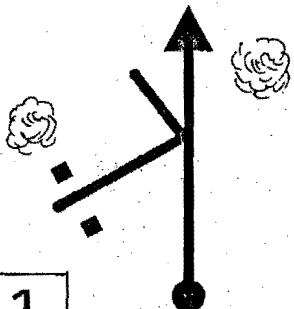

0,14

● cimitero

0,14

0,14

2

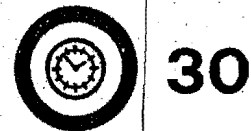
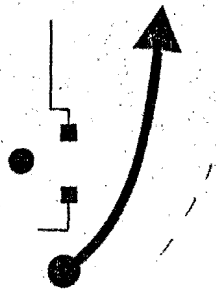

0,00

!o RIORDINAMENTO
CONTROLLARE
LA TABOULA

SECTEUR

9

CH30 LASCARI FINE RIORDINAMENTO

CH31 S.P.9

moy.

43,980

distance

22,070

temps
imparti

30'

distance

direction

informations

dist. tot.
regress.

tot.

part.

0.00

0.00

1

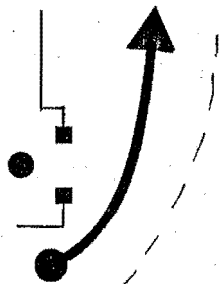

● cimitero



22.07

0.08

0.08

2

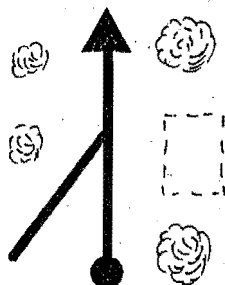

21.99

1.45

1.37

3

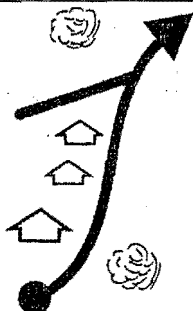

20.62

6.06

4.61

4

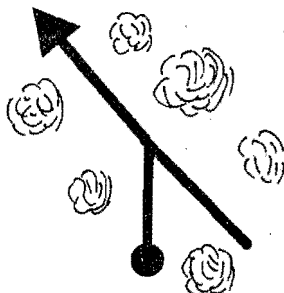

16.01

8.78

2.72

5

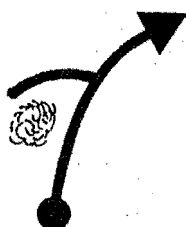

13.29

CH 30 - LASCARI FINE RIORDINAMENTO

CH 31 - S.P. 9

KM. 22,070 - 30'

distance		direction	informations	dist. tot. regress.
tot.	part.			
10,43	1,65		<ul style="list-style-type: none"> ● GRATERI 	11,64
10,74	0,31		<ul style="list-style-type: none"> ● ISNELLO ● GRATERI ★ abbeveratoio POSTAZIONE INTERMEDIA ! (vertical bar) ● ☒ ☒ ⊗ 	11,33
11,09	0,35		<ul style="list-style-type: none"> ! (vertical bar) ▲ ● ★ abbeveratoio 	10,98
11,24	0,15		<ul style="list-style-type: none"> ! (vertical bar) ! (vertical bar) ▲ ● ● 	10,83
11,35	0,11		<ul style="list-style-type: none"> ! (vertical bar) ▲ ● 	10,72

CH 30 - LASCARI FINE RIORDINAMENTO

CH 31 - S.P. 9

KM. 22,070 - 30'

distance		direction	informations	dist. tot. regress.
tot.	part.			
13.06	1.71	11 	<p>● cava</p>	9.01
16.33	3.27	12 	 	5.74
16.54	0.21	13 	<p>● SANTUARIO GIBILMANNA </p> <p></p> <p>●</p> <p>ISNELLO CASTELBUONO COLLESANO CEPALU'</p>	5.53
16.61	0.07	14 	 	5.46
18.19	1.58	15 	<p>150</p> 	3.88

CH 30 - LASCARI FINE RIORDINAMENTO





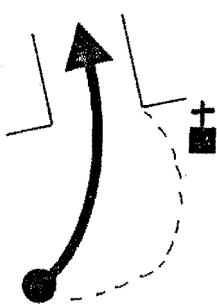
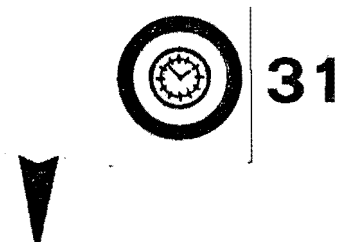

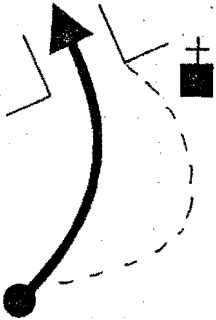

CH 31 - S.P. 9

Km. 22,070 - 30'

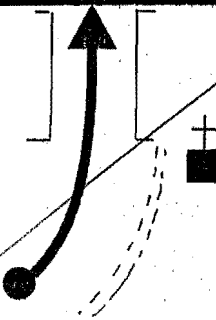
distance		direction	informations	dist. tot. regress.
tot.	part.			
22.07	3.88			0.00

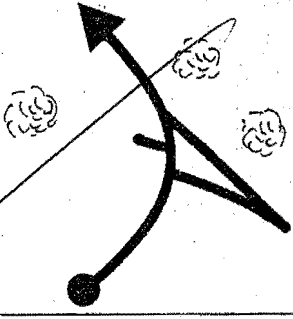
↓
ANDATA FINO A BIVIO

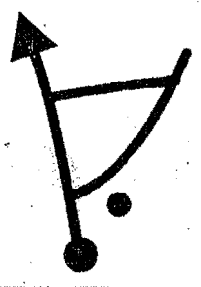
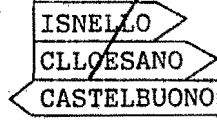

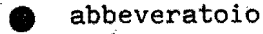







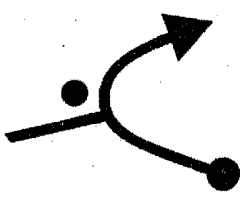

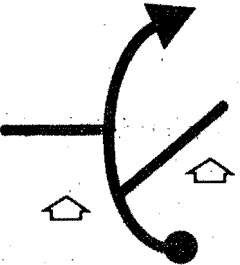

SECTEUR 10		CH 31 S.P.9		41.85	
		CH 41 CEFALU' LUNGOMARE		distance 42,390	
				temps imparti 1 ^H 01'	
distance		direction	informations	dist. tot. regress.	
tot.	part.				
0,00	0,00	1		 31	42,39
0,05	0,05	2		 H2 	42,34
0,95	0,90	3			41,44
1,55	0,60	4			40,84
3,06	1,51	5			39,33

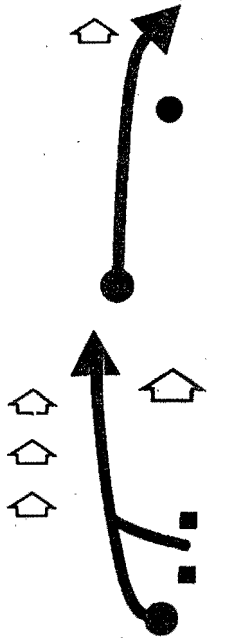
CH 31 - S.P. 9

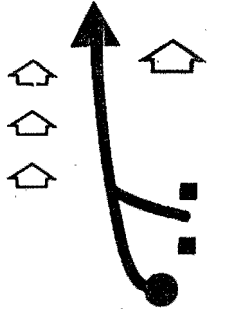
CH 41 - CEFALU' LUNGOMARE

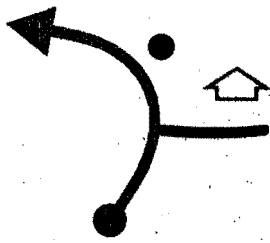
KM. 42,390 - 1^H 01'

distance		direction	informations	dist. tot. regress.
tot.	part.			
5,11	2,05	 6	● CAVA AQUILEIA POSTAZIONE INTERMEDIA    	37,28
8,16	3,05	 7		34,23
10,48	2,32	 8	● CASTELBUONO ▼ via Isnello ▼  H2	31,91
10,55	0,07	 9		31,84
10,83	0,28	 10	● abbeveratoio  	31,56

CH 31 - S.P. 9

CH 41 - CEFALU' LUNGOMARE









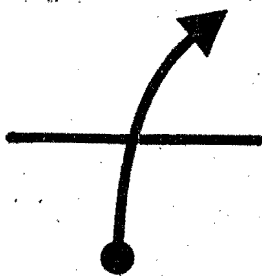
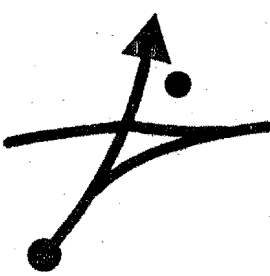

KM. 42,390 - 1^H 01'

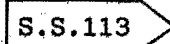
distance		direction	informations	dist. tot. regress.
tot.	part.			
11,01	0,18		<p>via Mario Levante</p> <p>● </p> <p>▲</p> <p>▲</p> <p>via Cavour</p> <p>▼</p>	<p>(+25)</p> <p>10 FPS</p> <p>31,38</p>
11,19	0,18		<p>▲</p> <p>via 18 Aprile 1867</p> <p>● </p> <p>★ </p>	<p>31,20</p>
11,45	0,26		<p>▲</p> <p>via Geraci</p> <p>● </p> <p>▼</p> <p>● </p>	<p>30,94</p>
11,75	0,30		<p>97</p> <p>50</p> <p>▲</p> <p>via Geraci</p> <p>● </p> <p>▼</p> <p>● </p>	<p>30,64</p>
11,88	0,13		<p>▲</p> <p>via Geraci</p> <p>● </p> <p>▼</p> <p>● </p>	<p>30,51</p>

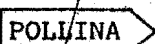
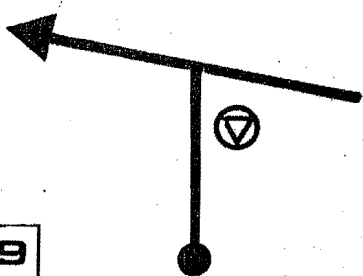
CH 31 - S.P. 9

CH 41 - CEFALU' LUNGOMARE

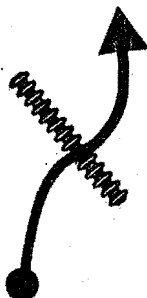
KM. 42,390 - 1^H 01'

distance		direction	informations	dist. tot. regress.
tot.	part.			
11,95	0,07	16 		30,44
12,81	0,86	17 	 S.S. 286   S.S.113	29,58
22,16	9,35	18 	  POLLINA <i>11/30 10'13</i>	20,23
31,66	9,50	19 	 S.S.113 <i>17/30 16'10</i>  	10,73
31,71	0,05	20 	 	10,68

CH 31 - S.P. 9

CH 41 - CEFALU' LUNGOMARE

KM. 42,390 - 1^H 01'

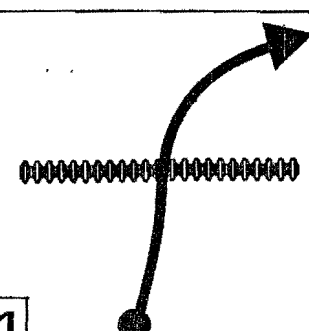
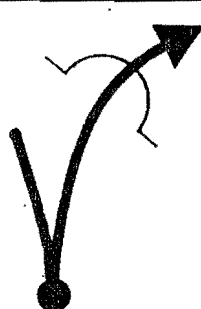
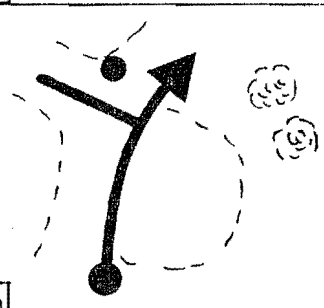
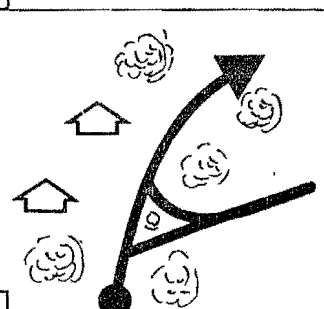
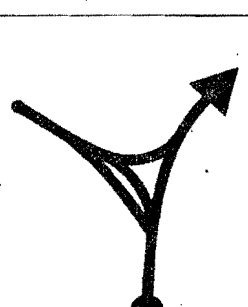
distance		direction	informations	dist. tot. regress.
tot.	part.			
34,26	2,55	<div style="border: 1px solid black; padding: 2px;">21</div> 	<p>2030 18'30</p> <p>!</p>	8,13
36,75	2,49	<div style="border: 1px solid black; padding: 2px;">22</div> 	<p>2030 20'25</p>	5,64
39,52	2,77	<div style="border: 1px solid black; padding: 2px;">23</div> 	<p>25</p> <p>FERLA 23'</p> <p>!</p>	2,87
40,14	0,62	<div style="border: 1px solid black; padding: 2px;">24</div> 	<p>2500 24'</p>	2,25
41,26	1,12	<div style="border: 1px solid black; padding: 2px;">25</div> 	<p>2500</p> <p>A19 CATANIA PALEOMO A20</p> <p>25'25</p> <p>!!</p>	1,13

CH 31 - S.P. 9

CH 41 - CEFALU' LUNGOMARE

Km. 42,390 - 1^H 01'

distance		direction	informations	dist. tot. regress.
tot.	part.			
41,47	0,21			0,92
41,58	0,11			0,81
41,69	0,11		<p>via Cavour</p> <p><i>2030</i></p>	0,70
42,01	0,32			0,38
42,39	0,38		<p><i>2730</i></p>	0,00

SECTEUR

11

CH 41 CEFALU' LUNGOMARE

CH 42 CEFALU' PARCO CHIUSO

distance

0,440

temps

imparti

10'

distance

tot.

part.

direction

informations

dist. tot.

regress.

0,00

0,00

1

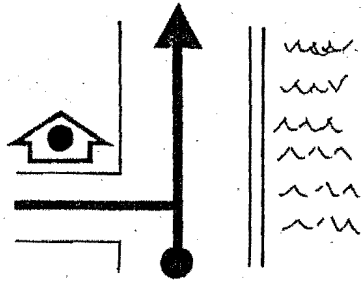

● hotel



41

0,44

0,25

0,25

2

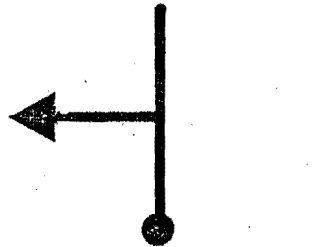

0,19

0,30

0,05

3

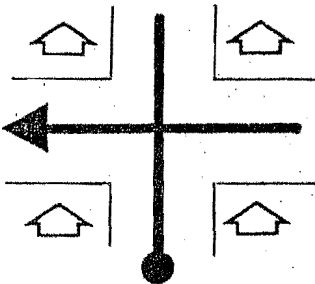

0,14

0,44

0,14

4

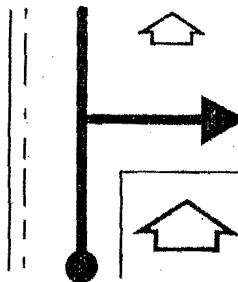

42

0,00